

MEGAPHASE FACTORY FORM RIGHT ANGLE



Unique Permanent Right Angle Design

The Factory Form Right Angle design will extend the life of your cable assemblies without sacrificing electrical performance.

MegaPhase designed the Factory Form Right Angle as a replacement for right-angled connectors and test adapters. The unique permanent curved flexure minimizes electrical reflection and loss found in right-angled connectors and adapters.

It provides the necessary space needed for cable mate/de-mate processes. This design option is available on most MegaPhase Test and Measurement and RF Cables.

Specifications

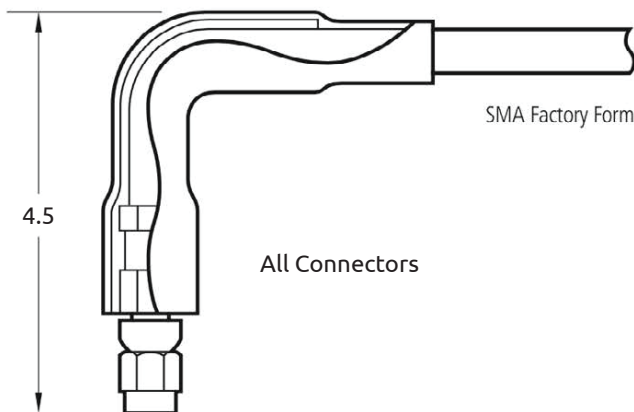
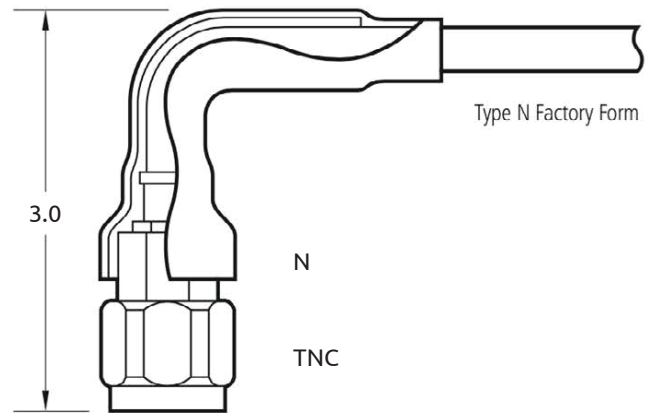
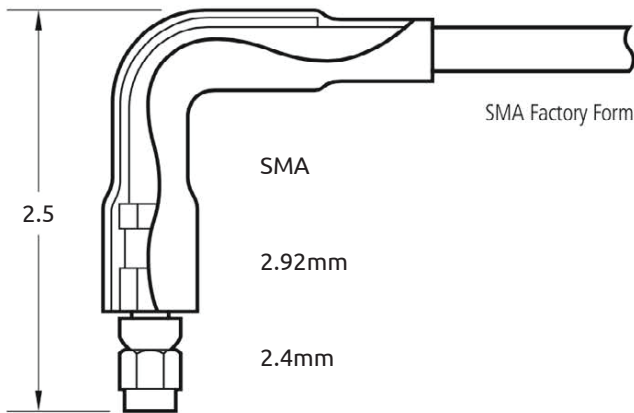

Armored Cables





MegaPhase®

With the right connection anything is possible

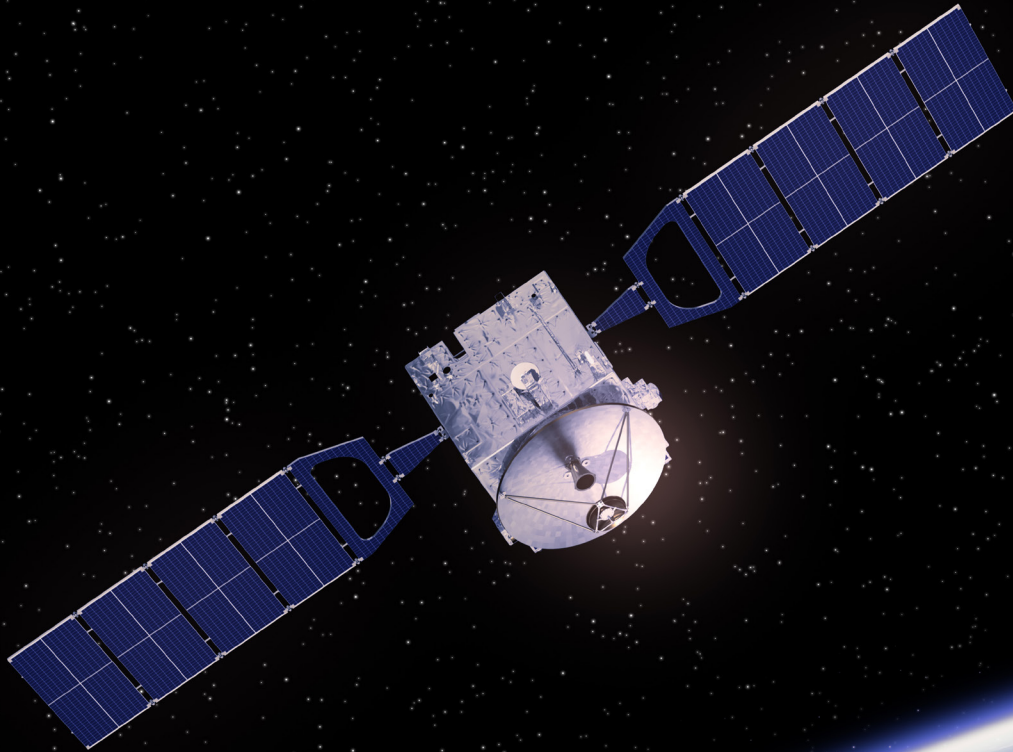

[Visit us at megaphase.com](http://megaphase.com)

About us

Founded in 1998 and headquartered in Stroudsburg, Pennsylvania, MegaPhase designs and manufactures high-performance RF coaxial cables and connectors for OEMs in critical markets including test instrumentation, defense, aerospace, telecommunications, and satellite systems. Serving more than 500 customers in 30 countries—including major technology leaders and the U.S. government—MegaPhase is best known for its industry-leading GrooveTube® technology, a breakthrough flexible cable design used in high-reliability, high-power, and phase-defined applications across ground, sea, air, and space platforms. All products are manufactured in-house, tested 100% in a state-of-the-art RF lab up to 110 GHz, and engineered to deliver exceptional phase stability, low loss, and long-term measurement repeatability, helping customers achieve more reliable results at a lower cost per measurement.

MegaPhase

122 Banner Road, Stroudsburg, PA 18360-6433 | Tel: 570-424-8400 | Solutions@MegaPhase.com